

Cw cavity ring down spectroscopy in a pulsed planar plasma expansion

P. Birza, T. Motylewski, D. Khoroshev, A. Chirokolava, H. Linnartz, J.P. Maier*

Institute for Physical Chemistry, University of Basel, Klingelbergstrasse 80, CH-4056 Basel, Switzerland

Received 24 January 2002; accepted 15 February 2002

Abstract

A cw cavity ring down spectrometer has been constructed with the aim to record electronic spectra of rotationally cold carbon chain radicals at high spectral resolution in direct absorption. The radicals are generated in a discharge of a high pressure gas pulse of acetylene in helium in a multilayer slit nozzle. A passive cavity mode locking scheme is used to handle refractive index changes inside the cavity caused by gas pulse and plasma fluctuations. The performance is demonstrated on the rotationally resolved origin band spectrum of the $A^2\Pi_g - X^2\Pi_u$ electronic transition of the triacetylene cation, HC_6H^+ , around 16654.7 cm^{-1} . © 2002 Elsevier Science B.V. All rights reserved.

1. Introduction

High resolution spectra of unsaturated carbon chain radicals are of interest in view of their role in interstellar hydrocarbon chemistry. Species of the form C_nH , C_nN , $HC_{2n+1}N$ and H_2C_n , with chains containing as many as 11 carbon atoms, have been identified in the dense interstellar medium with the aid of laboratory Fourier transform microwave spectroscopy [1]. It has been argued that electronic transitions of such chains may be among the carriers of unidentified absorption features in diffuse interstellar clouds [2]. The first experimental indication of this came from observations of the electronic absorption spectra of mass-selected carbon

species in neon matrices [3], but owing to solvation effects, the absorption bands exhibit a shift relative to the corresponding gas phase spectra. The latter are now available from a series of experiments on supersonic plasma expansions, using photo-detachment [4], REMPI-TOF [5], and cavity ring down (CRD) [6] spectroscopy with pulsed laser systems. The frequency resolution in these experiments is typically of the order of 0.035 cm^{-1} or worse. In a single-mode cw laser experiment a much higher resolution can be obtained and with this aim a cw cavity ring down setup has been constructed.

Cavity ring down spectroscopy has become a powerful tool for the study of the structural and dynamical properties of molecules in the gas phase. In a series of recent review articles [7–9] a number of useful applications is listed. One of the reasons for this success is the conceptual simplicity

* Corresponding author. Fax: +41-61-267-38-55.

E-mail address: j.p.maier@unibas.ch (J.P. Maier).

of a CRD experiment [10]. A small fraction of laser light is coupled into an optical cavity of length L consisting of two mirrors with a reflectivity $R \sim 99.99\%$ or better. The rate of light leaking out of the cavity has an envelope which is simply a first order exponential decay, $\exp(-t/\tau)$. The ring down time τ is given by $L/[c(1 - R + \alpha l)]$, where c is the speed of light and αl reflects the absorbance for a sample present in the cavity with absorption coefficient α and length l . That is, the ring down time reflects the rate of absorption rather than its magnitude and as such it is independent of power fluctuations. In addition, very long absorption pathlengths are obtained by confining light tens of microseconds to the cavity. This increases the sensitivity considerably and absorption values as small as 10^{-6} per pass have been detected.

In conventional CRD experiments pulsed lasers are used; each light pulse induces a ring down event. In cw experiments this is not the case and more complicated detection schemes must be applied; either by measuring the phase retardation of an amplitude modulated cw laser [11] or by analysing the exponential decay after switching off the laser beam with a fast optical switch [12–17]. In addition, the cavity has to be in resonance with the laser wavelength, because the bandwidth is generally too narrow to excite more than one cavity mode at a time. For this reason several active tracking schemes have been developed [13,14,16], but in a pulsed jet experiment – as it is the case here – such schemes do not work: the gas pulse changes the refraction index, effectively changing the optical length of the cavity, pushing it out of resonance. This effect is further enhanced when plasma fluctuations cause additional instabilities. In this case a passive scheme for mode locking must be used, as it was introduced by Quack and coworkers [15,17].

In this contribution the experimental details are described of a cw CRD setup capable of detecting unstable carbon chains generated in a pulsed supersonic planar plasma expansion. The performance is discussed on the example of a rotationally resolved electronic spectrum of the triacetylene cation, HC_6H^+ .

2. Experimental

The carbon chain radicals are generated by applying a 500 μs high voltage pulse (-600 V, 100 mA) to a 1 ms high pressure gas pulse of a 0.5% HCCH/He mixture that is expanded through a 3 cm \times 200 μm slit with a backing pressure of 10 to 12 bar. The system has been used in other studies (see e.g. [18]) and combines high molecular densities and relatively large absorption path lengths with an effective adiabatical cooling. In addition, the effective resolution is increased compared to pinhole expansions due to a reduced Doppler broadening parallel to the slit. A further reduction is obtained by using a multichannel body. A 3D picture of the nozzle is shown in Fig. 1 together with a short description of its operation. More details are available in [19].

Fig. 2 shows the whole experimental setup. The light of a single mode ring dye laser (Coherent, cw-899 autoscan), pumped by a 6 W solid state laser, is guided through an acousto-optical modulator (AOM). The first order deflection is focused into the ring down cavity via a lens that matches a TEM_{00} cavity mode, where it crosses the planar plasma expansion 6 mm downstream. The CRD mirrors (1 m plano/convex, $R > 99.995\%$) are mounted in a mechanically stable holder at a distance of $L = 32$ cm. A system of internal diaphragms facilitates the alignment and He-curtains protect the mirrors during jet operation from pollution.

A strong transmission occurs only when cavity and laser wavelength are mode matched. To achieve this a passive mode locking system has been used, similar to the method described in [15,17], with several small modifications. One of the mirrors is mounted on a piezo element and by applying a periodical (30 Hz) triangular shaped voltage to the element the cavity length is modulated. The amplitude is chosen in such a way that it corresponds to at least two free spectral ranges of the laser frequency, i.e. the cavity is at least four times in resonance with the laser during one period (Fig. 3). A resonance results in a maximum of transmitted light intensity after the cavity and is monitored using an oscilloscope. When the intensity reaches a certain threshold, a trigger signal is

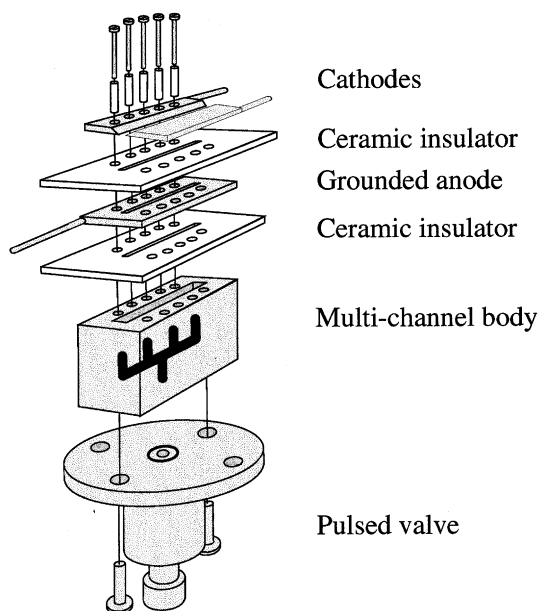

Fig. 1. Artist's view of the high pressure slit nozzle discharge. The orifice consists of two sharp stainless steel jaws (that form the actual slit), a ceramic insulator, a slotted metal plate (grounded) and a second ceramic insulator. Both insulators and metal parts are mounted to the body of the nozzle using electrically isolated screws. A pulsed negative high voltage is applied to the jaws via ballast resistors at the moment that a high pressure gas pulse expands through the channel. The discharge strikes to the grounded plate, localising the reaction zone to a region upstream of the expansion. The body is floating and connected to an electromagnetic driven pulsed valve. A multi-channel system inside the nozzle regulates the gas flow towards the slit and allows a further reduction of the Doppler broadening.

generated that switches off the AOM; the laser beam is interrupted and a ring down event is initiated.

The following detection scheme is used to guarantee that plasma pulse and ring down event coincide (Fig. 3). The data acquisition programme chooses via a simple algorithm the transmission that is strongest and closest to the middle of the ramp voltage. This defines t_0 . The exact ramp voltage at which this cavity resonance occurs is used to define a 300 μs time window at the same ramp voltage in the next cycle. (In order to minimise hysteresis effects of the piezo element, only transmissions on positive or negative ramps are used.) It also defines a delay at which gas and

discharge pulse are activated, in such a way that the plasma expansion coincides with the time window: when a ring down event occurs it automatically samples the plasma. The new resonance defines t_1 and is used to predict the next resonance around t_2 , etc., effectively chasing the resonance. To further increase the sensitivity, only every second cycle is used to trigger gas and discharge pulse. The plasma free ring down event ($\tau_{\text{reference}}$) is then used for background subtraction. This means that with a 30 Hz periodic modulation, 15 ring down events with plasma and 15 ring down events without plasma are measured. The major part of the predicted resonances is within the 300 μs time window, but due to external instabilities the procedure might fail. In this case the data acquisition programme checks the whole ramp, defines a new t_0 and restarts predicting the position of the next resonance. During this short time (3 cycles) only a few data points are lost.

The transmission after the ring-down cavity is focused via a narrow band pass filter onto a broad wavelength band Si-photodiode and recorded in real-time linux using a 12 bit ADC card and a COMEDI driver [20]. The complete decay curve is fitted to an exponential defining τ . The CRD spectrum is obtained by recording $(1/\tau_{\text{plasma}} - 1/\tau_{\text{reference}})$ while scanning the laser. Typical ring down times are $\tau = 27 \mu\text{s}$. This is equivalent to approximately 25'000 passes through the plasma or an effective absorption pathlength of 760 m.

3. Results

In the lower trace of Fig. 4 the rotationally resolved origin band of the $A^2\Pi_g - X^2\Pi_u$ electronic transition of HC_6H^+ is shown. The same transition has been studied in detail before in a liquid nitrogen cooled hollow-cathode discharge cell applying frequency-plasma double modulation (FPM) spectroscopy [21] and is shown for comparison in the upper trace of Fig. 4. At the high ambient temperature in the cell (approximately 150–200 K) the band system is found to comprise the two $A^2\Pi_{3/2} - X^2\Pi_{3/2}$ and $A^2\Pi_{1/2} - X^2\Pi_{1/2}$ subbands, partially overlapping and separated by the difference in spin-orbit constants in ground and elec-

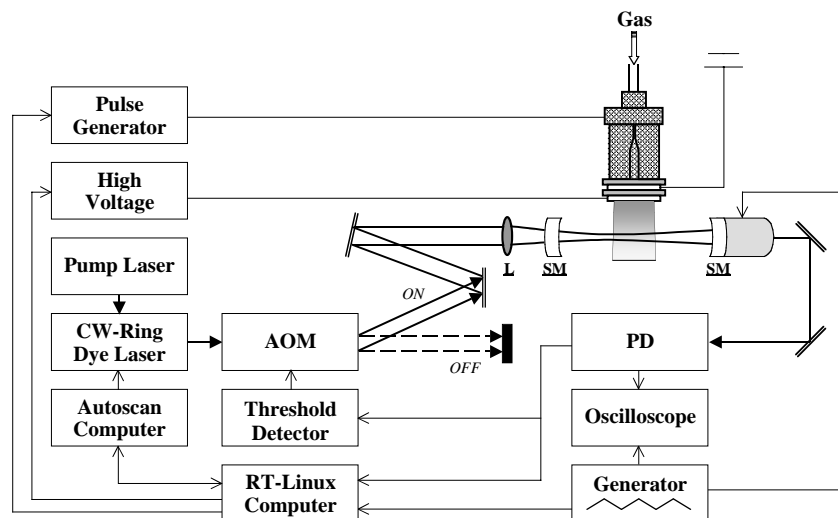

Fig. 2. Schematic of the experimental setup. Details are given in the text.

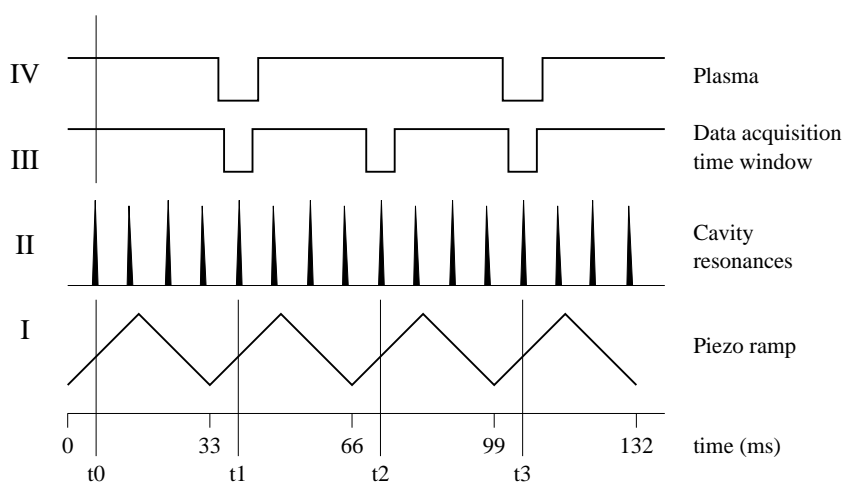

Fig. 3. Timing and triggering scheme. (I) A 30 Hz ramp is applied to a piezo element. (II) The photo diode shows when cavity resonances occur. The data-acquisition programme chooses the transmission closest to the middle of the ramp, defining t_0 and the ramp voltage for which the resonance occurs. When the transmission intensity exceeds a certain threshold, the AOM is switched off and a ring down event is induced. (III) The programme defines a 300 μ s time window in which the next resonance is expected. In order to circumvent hysteresis effects only signals on positive or negative ramps are taken. The example is shown for a positive ramp. (IV) t_0 is also used to trigger the gas and discharge pulse every second ramp. The plasma free ring down event is used for background subtraction.

tronically excited state. Both subbands show strong P- and R-branches, with clear red shaded bandheads and with a weak Q-branch. The spectral simplification upon jet cooling is striking: the jet spectrum displays only one single band. It

consists of well-defined P- and R-branches and a strong Q-branch (Fig. 4). The lower J -levels are markedly stronger and no band head is observed. This is consistent with the low temperature in the supersonic jet. From the relative intensity of

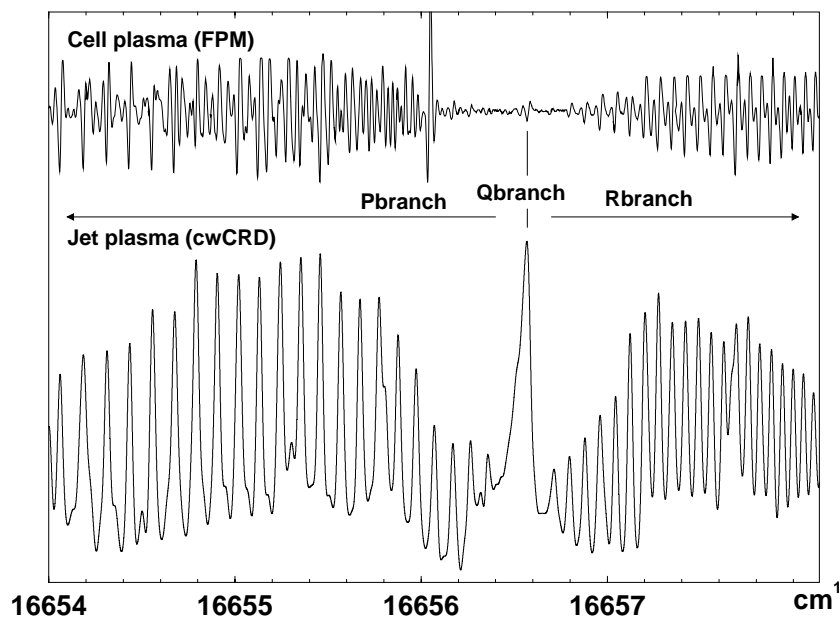

Fig. 4. The origin band of the $A^2\Pi_g - X^2\Pi_u$ electronic spectrum of triacetylene cation, HC_6H^+ , measured by cw CRD spectroscopy through a supersonic pulsed planar plasma with $T_{rot} \sim 15$ K (lower trace). The upper trace shows the corresponding cell spectrum using frequency-plasma double modulation spectroscopy with $T_{rot} \sim 170$ K [21].

subsequent J -levels a rotational temperature of the order of 10 to 15 K is derived. The lower temperature favours the population of the low- J rotational levels and as the Q-line strength is highest for low J -values the Q-branch is now much more pronounced. The spin-orbit splitting in the ground state is about -31 cm^{-1} and as a consequence only the lower ($\Omega = \frac{3}{2}$) spin-orbit component is observed.

The best achievable linewidth (FWHM), using a multichannel body was 450 MHz, two to three times smaller than possible up to now in pulsed laser experiments. This is sufficient to obtain rotational resolution for linear chains with 10 to 11 carbon atoms, as long as no lifetime broadening is involved. However, 450 MHz is still considerably larger than expected from the few MHz bandwidth of the cw laser system. Assuming a Doppler-broadened signal, this corresponds to a translational temperature of the order of 125 K. Indeed, this is due to residual Doppler broadening in the slit expansion, as has been observed before in FPM experiments [22]: the use of a slower expansion gas (for example Ar) reduces the achievable

linewidth proportional to the speed ratios. Clearly, further modifications in the expansion source are necessary to take advantage of the small bandwidth of the cw laser used. A possible improvement could be the use of skimmed planar expansions but such systems have not been reported in the literature yet. Furthermore, it might well be possible that molecular ions diffuse out of the expansion because of charge effects.

The present technique is an extension of previous work in which the same discharge source has been used in combination with a pulsed CRD [19] and a cw frequency-plasma double modulation [23] detection scheme. All three techniques – pulsed CRD, cw-CRD and FPM – have their own advantages and disadvantages.

The pulsed CRD is particularly suited for fast scans. A spectrum comparable to the one shown in Fig. 4 takes less than 20 min to record, whereas the two cw techniques need at least 1.5 h. In addition, special boxcar integration schemes are necessary to compensate for the low duty cycle that is typical when combining a cw detection with a pulsed production technique. The achievable resolution,

on the other hand, is substantially higher in the cw experiments and at this stage only limited by residual Doppler broadening in the expansion. The CRD experiments are generally applicable, whereas the application of the FPM experiment is restricted to absorption lines that are not broadened beyond the modulation amplitude (~ 400 MHz). The resulting line shape is a $1f$ derivative as shown in the upper trace of Fig. 4.

The best achievable S/N ratios are comparable for the three methods. This is achieved by *noise reduction* in the FPM experiment – both laser and plasma noise are reduced in a phase sensitive detection scheme – and by *signal improvement* in the CRD experiments – here the effective absorption path length is increased.

4. Conclusion

It has been shown that cw CRD spectroscopy is a sensitive and generally applicable method to study rotationally cold carbon chain radicals that are produced in a pulsed plasma expansion. The method will be particularly useful in the study of long species with small rotational constants. Passive mode matching is sufficient to perform the experiments. A reduction in linewidth has been obtained. The limiting factor turns out to be residual Doppler broadening in the expansion along the slit.

Acknowledgements

We thank Dr. M. Hippler and Prof. M. Quack for generously sharing their expertise in cw CRD. This work has been supported by the Swiss National Science Foundation, grant 20.63459.00. One of the authors (H.L.) also acknowledges support from FOM (Fundamenteel Onderzoek der Materie).

References

- [1] M.C. McCarthy, P. Thaddeus, Chem. Soc. Rev. 30 (2001) 177, and references therein.
- [2] A.G.G.M. Tielens and T.P. Snow, (Eds.), The diffuse interstellar bands, Dordrecht, 1995, pp. 175–238.
- [3] J.P. Maier, J. Phys. Chem. A. 102 (1998) 3462.
- [4] D.A. Kirkwood, M. Tulej, M.V. Pachkov, M. Schnaiter, F. Guthe, M. Grutter, M. Wyss, J.P. Maier, G. Fischer, J. Chem. Phys. 111 (1999) 9280.
- [5] T. Pino, H.B. Ding, F. Guthe, J.P. Maier, J. Chem. Phys. 114 (2001) 2208.
- [6] T. Motylewski, H. Linnartz, O. Vaizert, J.P. Maier, G.A. Galazutdinov, F.A. Musaev, J. Krelowski, G.A.H. Walker, D.A. Bohlender, Astrophys. J. 531 (2000) 312.
- [7] J.J. Scherer, P.B. Paul, A. O'Keefe, R.J. Saykally, Chem. Rev. 97 (1997) 25.
- [8] M.D. Wheeler, S.M. Newman, A.J. Orr-Ewing, M.N.R. Ashold, J. Chem. Soc. Faraday Trans. 94 (1998) 337.
- [9] G. Berden, R. Peeters, G. Meijer, Int. Rev. Phys. Chem. 19 (2000) 565.
- [10] A. O'Keefe, D.A.G. Deacon, Rev. Sci. Instrum. 59 (1988) 2544.
- [11] R. Engeln, G. von Helden, G. Berden, G. Meijer, Chem. Phys. Lett. 262 (1996) 105.
- [12] D. Romanini, A.A. Kachanov, N. Sadeghi, F. Stoeckel, Chem. Phys. Lett. 264 (1997) 316.
- [13] D. Romanini, A.A. Kachanov, F. Stoeckel, Chem. Phys. Lett. 270 (1997) 538.
- [14] B.A. Paldus, C.C. Harb, T.G. Spence, B. Wilke, J. Xie, J.S. Harris, R.N. Zare, J. Appl. Phys. 83 (1998) 3991.
- [15] Y. He, M. Hippler, M. Quack, Chem. Phys. Lett. 289 (1998) 527.
- [16] M. Murtz, B. Frech, W. Urban, Appl. Phys. B. 68 (1999) 243.
- [17] M. Hippler, M. Quack, Chem. Phys. Lett. 314 (1999) 273.
- [18] H. Linnartz, D. Pfluger, O. Vaizert, P. Cias, P. Birza, D. Khoroshev, J.P. Maier, J. Chem. Phys. 116 (2002) 924, and references therein.
- [19] T. Motylewski, H. Linnartz, Rev. Sci. Instrum. 70 (1999) 1305.
- [20] See D. Schleaf, Linux Control and Measurement Device Interface, <ftp://stm.lbl.gov/pub/comedi/>.
- [21] W.E. Sinclair, D. Pfluger, H. Linnartz, J.P. Maier, J. Chem. Phys. 110 (1999) 296.
- [22] D. Pfluger, W.E. Sinclair, H. Linnartz, J.P. Maier, Chem. Phys. Lett. 313 (1999) 171.
- [23] D. Pfluger, T. Motylewski, H. Linnartz, W.E. Sinclair, J.P. Maier, Chem. Phys. Lett. 329 (2000) 29.